

Перв. примен.
Справ. № 000073135
Подп. и дата
Изм. № дубл.
Взам. изм. №
Подп. и дата
Изм. № подл.

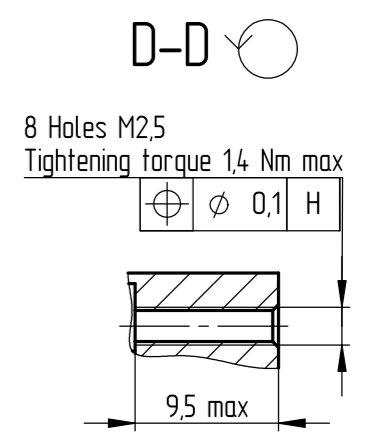
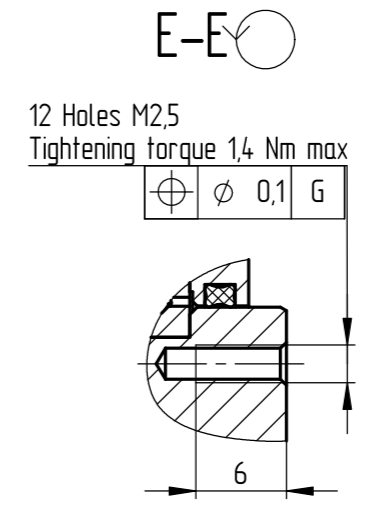
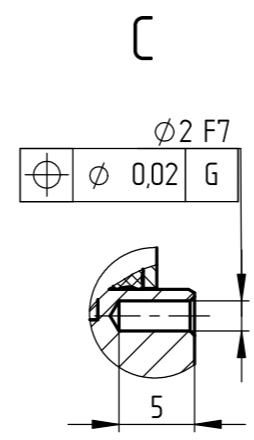
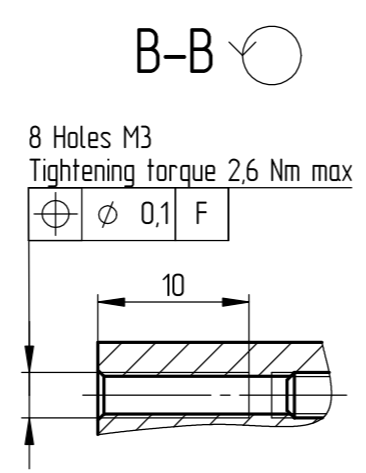
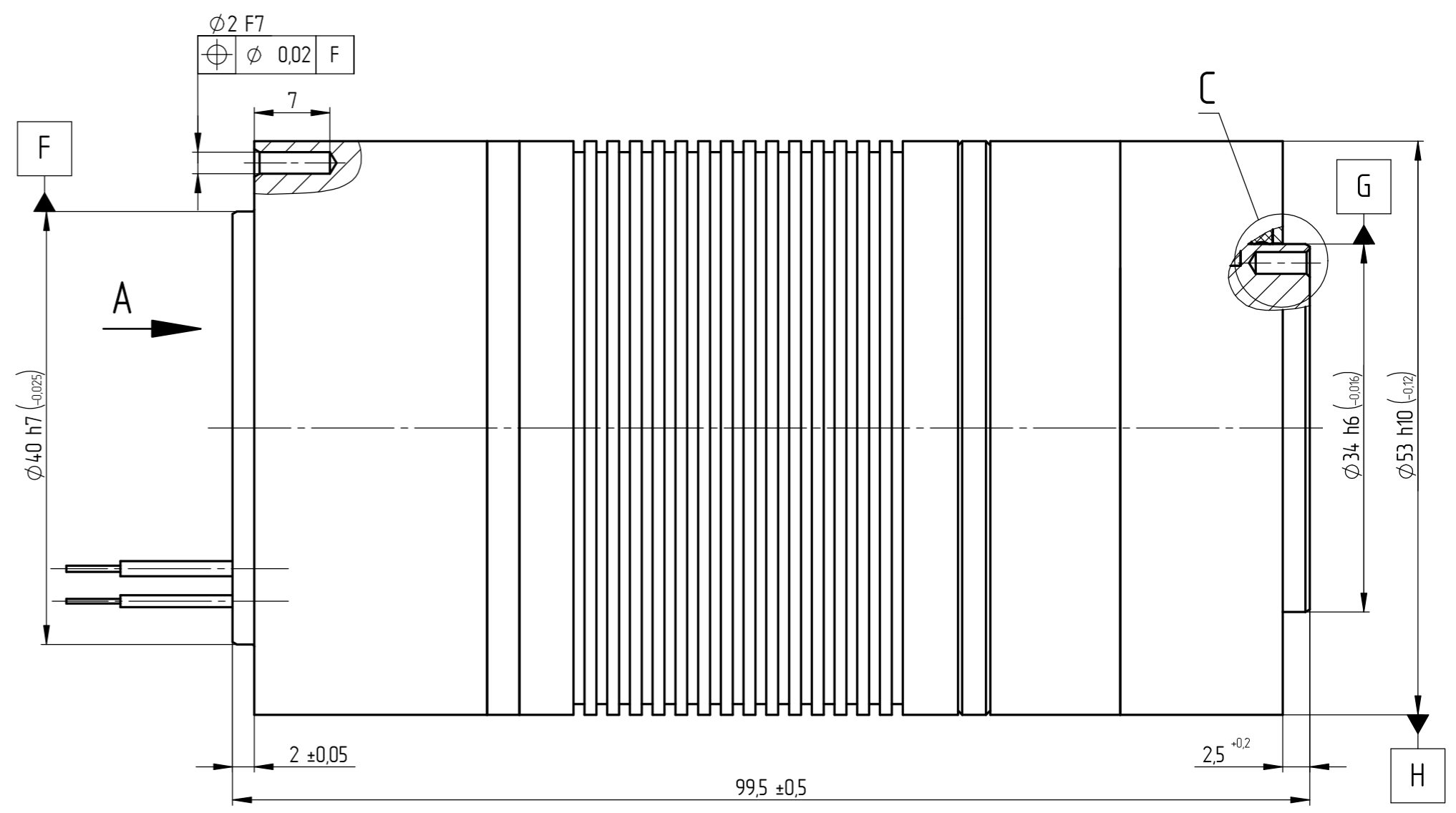
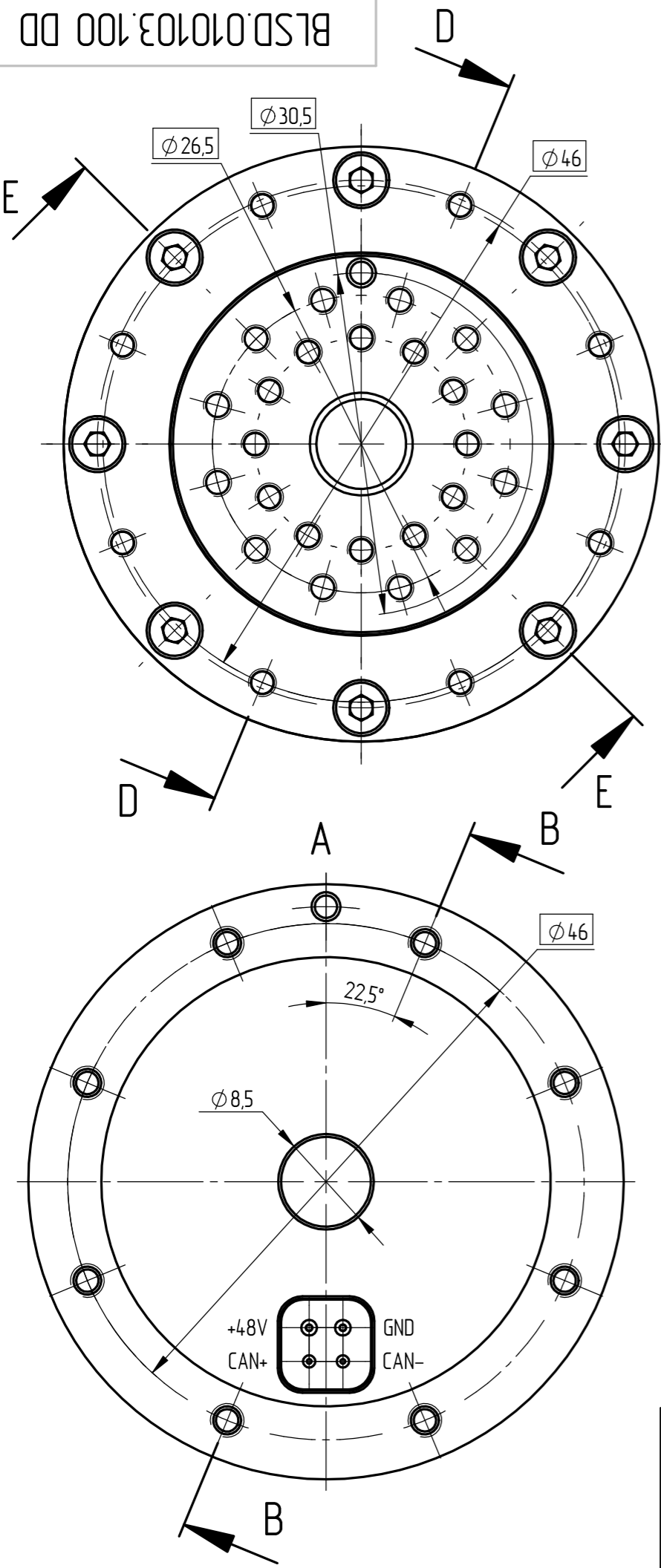

Metal-to-metal contacts between fasteners and mounting threaded holes function as PE

Pos. of lead	Color	Signal	Min. length, mm.
1	Red	48v AWG23	150
2	Black	Ground AWG23	
3	Brown	CAN+ AWG26	
4	Blue	CAN- AWG26	

(01)	Rev. Sheet	Document №	Signature	Date
	Designed by	Rabtsevich		02.12.19
	Checked by	T. check		
	Norm.check			
	Appr. by			

BLSD.010103.100 DD

Servomotor RDrive 50
Dimensional drawing

Letter	Weight	Scale
	0.897	2:1
Sheet	of sheets	

