

FMI601201 FRAMELESS MOTORS

USER MANUAL

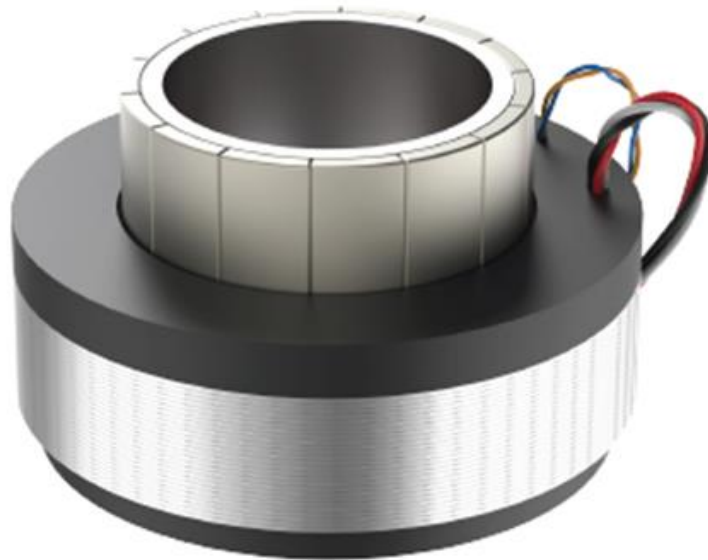

INTRODUCTION

FMI-series frameless motors by Rozum Robotics are designed to provide motion as part of a motion system. Available in a range of sizes (dia. 41, 51, 75 mm), FMI motors are suitable for a wide spectrum of applications—robotics, industrial machinery, automatic tools, etc.

This manual is intended for technicians and engineers who are responsible for integrating the FMI601201 frameless motor into a motion system, as well as operating the motor after integration. The document contains:

- basic features and components of FMI-series frameless motors
- a description of the FMI601201 supply package
- specifications and operating conditions of the FMI601201 frameless motor
- instructions to assemble and mount FMI frameless motors
- storage and transportation recommendations

WARNING SIGNS AND THEIR MEANINGS

Below are the warning symbols used throughout the manual and explanations of their meanings.



The sign denotes important information that is not directly related to safety, but that the user should be aware of.



The sign indicates important safety precautions the user should follow.

TABLE OF CONTENTS

INTRODUCTION	2
WARNING SIGNS AND THEIR MEANINGS	2
1 PRODUCT OVERVIEW	4
1.1 Basic features and components	4
1.2 Thermal sensors	5
1.3 Supply package and transportation	6
1.4 Additional equipment for building a motion system	6
Housing	6
Power supply	7
Bearing	7
Controller	7
Rotor shaft	7
2 SPECIFICATIONS AND DIMENSIONS	7
3 MOUNTING REQUIREMENTS	8
3.1 Mechanical interfaces	8
3.2 Stator mounting	8
3.3 Rotor mounting	9
3.4 Electrical interfaces	10
Wiring	10
Protective earthing	11
4 ASSEMBLY	11
4.1 Required tools and materials	11
4.2 Assembly instructions	12
4.3 Disassembly	12
5 OPERATING CONDITIONS	13
6 MAINTENANCE	13
7 TROUBLESHOOTING	13
8 STORAGE	14

1 PRODUCT OVERVIEW

1.1 Basic features and components

FMI-series motors are *frameless brushless alternating current (AC)* motors. Their *basic features* are as follows:

- Compact size and low weight
- High power density and high power-to-weight ratio
- Simple mounting and assembling

An FMI-series frameless motor kit comprises two components—a rotor assembly and a stator assembly.

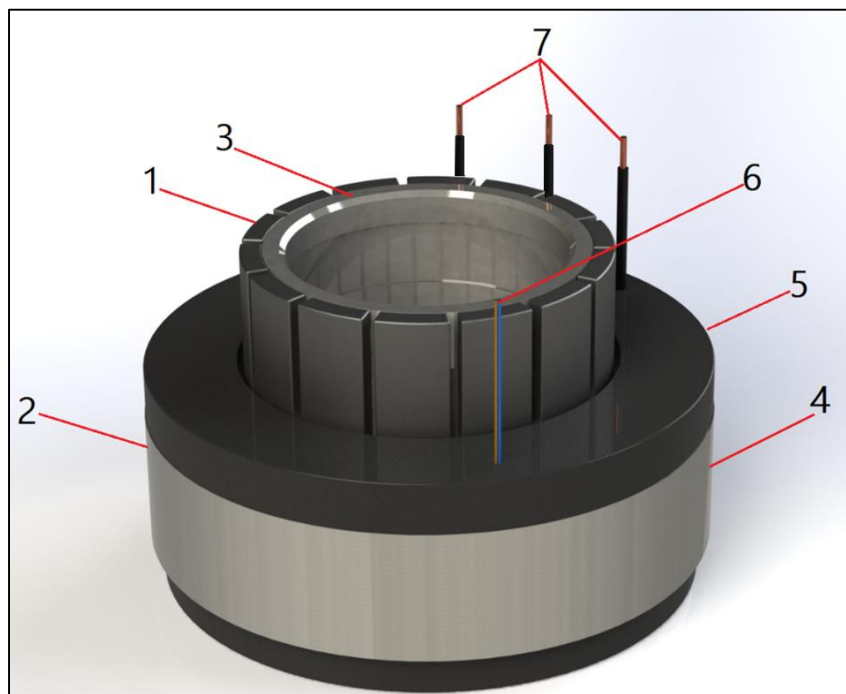

Figure 1-1: Rotor and stator assemblies with cable outputs

The rotor assembly

The rotor assembly (1) is the moving part of the frameless motor. The assembly contains magnets with alternating poles and a **support ring (3)**. The magnets are manufactured from rare-earth metals (neodymium or samarium-cobalt).



The rotor can also be supplied assembled with a shaft.

The stator assembly

The stator assembly (2) is the non-moving component of the FMI frameless motor. By design, the assembly is a 20 mm high **lamination stack** (4) with coil-supporting teeth. The stack consists of multiple 0.5 mm thick electrical steel plates. For improving thermal conductivity, it is covered with a special **polymer compound** (5).

The stator assembly also includes two **cable outputs**—one for the power cable (7) and the other for the thermal sensor cable (6).



The stator can also be supplied with a single cable output comprising both the power cable and the thermal sensor cables.

1.2 Thermal sensors

For overheating protection, FMI-series frameless motors are equipped with a thermal sensor—a negative temperature coefficient (NTC) thermistor (model NXFT15). The sensor is integrated into the stator winding and is in direct contact with it. When the thermistor senses increase in the temperature of the stator winding, its resistance decreases.

The NTC thermistor provides temperature sensing with accuracy of 0.1°C and has the following characteristics:

- Resistance at 25°C: 10 kOhm
- Beta constant at 25/85: 3434 K
- Maximum power: 100 mW
- Package/case: bead



For more information, refer to the manufacturer's documentation for the NXFT15 NTC thermistor.

Using cable output (6) (see **Figure 1-1**), you can connect the thermistor to a controller. The controller uses the thermistor readings to prevent overheating, cutting the motor off in case the maximum temperature setting is exceeded.

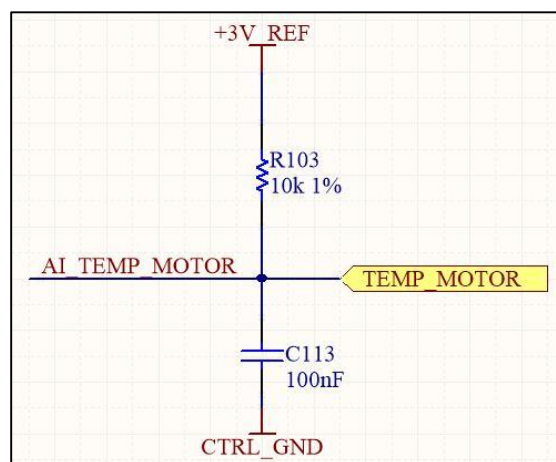

Figure 1-2: NTC thermistor interface in FMI motors

1.3 Supply package and transportation

The supply package of an FMI-series frameless motor comprises stator and rotor assemblies. The two assemblies are supplied separately in the same container as shown in **Figure 1-3** below.



Figure 1-3: An FMI-series frameless motor in a shipping container

We recommend using the shipping container for any further transportation of frameless motors.



Take extra care when unpacking the rotor and the stator to avoid any damage to their components. Do not handle the stator by wiring!

1.4 Additional equipment for building a motion system

Building a complete motion system with a FMI frameless motor will require using additional equipment, such as:

- A housing
- A power supply
- A bearing
- A controller
- A shaft



The additional equipment is usually out of Rozum Robotics supply scope. It is the integrator's responsibility to provide it.

Housing

The housing should be sufficiently rigid not to deform when you mount the stator in place. The inner diameter of the FMI601201 housing should be such as to comply with the ISO 51 H7 tolerance for the outer diameter of the stator.

On the inside, the housing should have a shoulder perpendicular to the stator mounting position. The shoulder is required to provide a clearance between the housing bottom and the stator lamination stack. For the FMI601201 frameless motor, the clearance should be at least 3 mm.



For better heat dissipation, you can also cut grooves on the outer surface of the housing.

Power supply

The power supply should have the same voltage and current ratings as indicated in the motor specifications (see **Table 2-1**).

Bearing

It is the entire responsibility of the integrator to provide a bearing to match the application requirements. When selecting a bearing, pay foremost attention to such operating parameters, as **speed**, **expected load**, and required **service life**.

Controller

You can either order a controller from Rozum Robotics or buy one from a third-party supplier.

The **recommended type** is a PWM controller of the following configuration:

- FOC sinusoidal control
- An absolute encoder as a feedback device
- Output current of 20 A continuous

Rotor shaft

Optionally, Rozum Robotics can supply its FMI frameless motors pre-assembled with a shaft. In other cases, make sure that the outer diameter of the selected shaft complies with the ISO 25 H7 tolerance as specified for the inner rotor diameter.

2 SPECIFICATIONS AND DIMENSIONS

Table 2-1 lists major technical specifications of FMI601201 frameless motors.

Table 2-1: Technical specifications of the FMI601201 frameless motor

Parameter	Value	Unit of measurement
<i>Mechanical</i>		
Weight	148	g
Rotor inertia	0.244	kg/cm ²
Stator diameter	51	mm
<i>Electrical</i>		
Winding type	Y	
Supply voltage	48	V
RMS current	4.2	A
Torque constant at 20°C, Kt	71	mN•m/A
Motor constant	74	mN•m/√W
Speed constant, Kv	123	RPM/V
Terminal resistance at 20°C	0.62	Ω
Terminal inductance	550	μH
Number of pole pairs	7	
<i>Performance</i>		
Power	166	W
Maximum efficiency	90	%
Rated torque	0,3	N•m
Peak torque	0,7	N•m
Rated speed	5,300	RPM
No load speed	5,900	RPM

3 MOUNTING REQUIREMENTS

3.1 Mechanical interfaces

For safe operation, it is essential to provide an air gap of at least 0.3 mm between the rotor and the stator. For the purpose, make sure to use 0.2 mm thick shim (e.g., made from mylar) when assembling the rotor with the stator (see **Section 4.2**).

3.2 Stator mounting

The preferred method for mounting the stator is **bonding**. We recommend using the Loctite 648 or 638 adhesive. Before applying the adhesive, make sure to clean the bonding surface (see **Figure 3-1**) with a suitable cleaning agent (e.g., acetone).

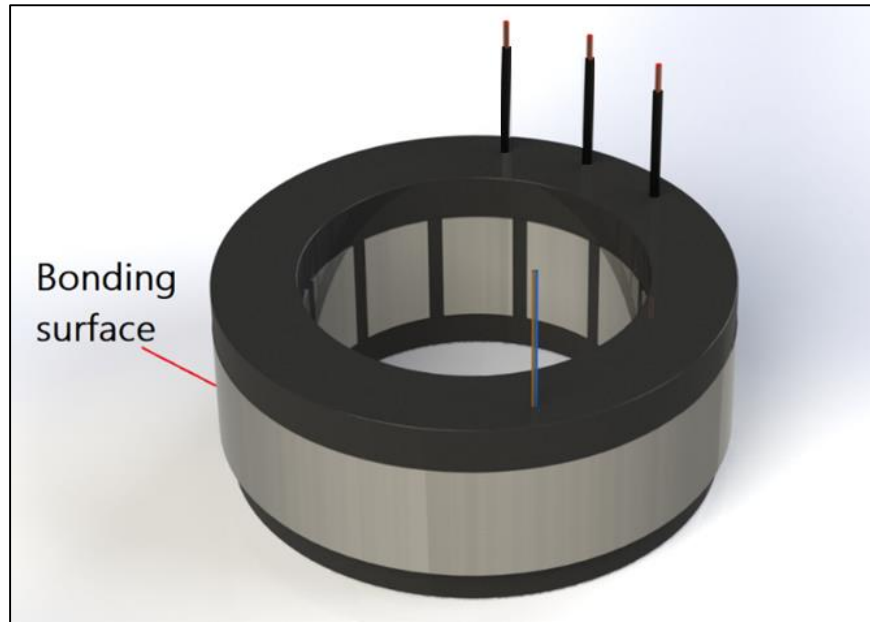

Figure 3-1: The bonding surface of the stator

3.3 Rotor mounting

A rotor can be mounted using one of the following two methods—**axial clamping** or **bonding**.



The choice of the mounting method depends on the application system design. Some of the possible considerations include heat transfer, stiffness, integration methods, and maintenance.

Axial clamping

This mounting method requires using a clamping ring. You need to position the clamping ring on the clamping surface (see **Figure 3-2**) and press it against the rotor ring.



The clamping ring should not contact the rotor magnets to avoid any damage to them.

Bonding

The recommended adhesive for bonding a stator is Loctite 648 or 638. Before applying the adhesive, make sure to clean the bonding surface with a suitable cleaning agent (e.g., acetone).

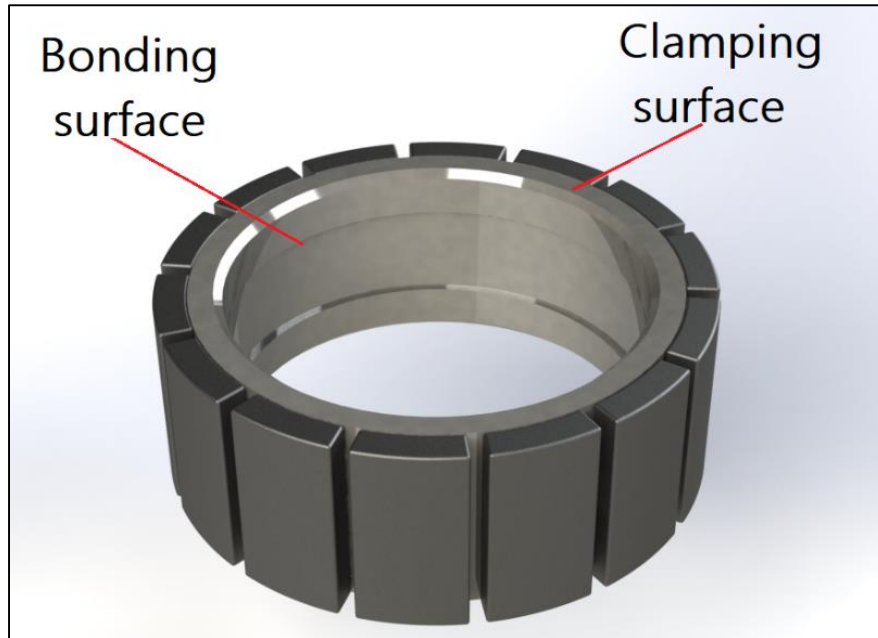

Figure 3-2: The mounting surfaces of the rotor



To avoid demagnetizing, never apply temperature above 70°C when curing the adhesive.

3.4 Electrical interfaces

Wiring

The wiring of FMI-series frameless motors comprises:

- a 3-phase power cable of Y-configuration (black)
- a 2-wire temperature sensor cable (blue and brown)

To provide electrical integration of the frameless motor into your application, use the wiring scheme in **Figure 3-3**.



Before starting wiring works, make sure to disconnect the motor and the application from power supply.

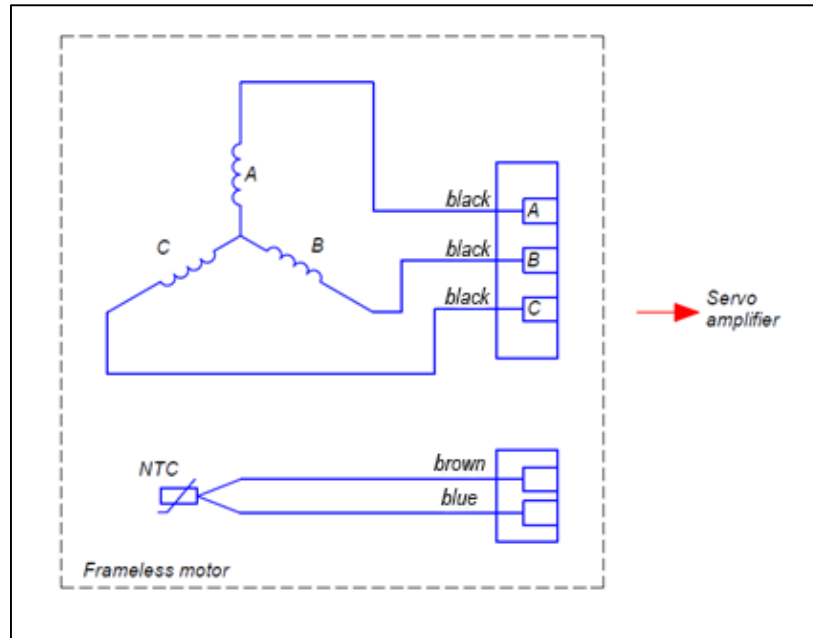

Figure 3-3: The wiring scheme for integrating FMI frameless motors

Protective earthing

It is the responsibility of the integrator to provide protective earthing of the motor housing. The protective earthing should comply with the following minimum requirements:

- Its current capacity should be at least equal to the current capacity of the motor wiring.
- The protective earthing wire should have the standard yellow/green insulation.
- Its voltage rating should correspond to the supply voltage of the motor winding as indicated in the specification (see **Table 2-1**).

You can either bundle the protective earthing wire with the motor wiring or run it separately, if your operating conditions require so.

4 ASSEMBLY

4.1 Required tools and materials

To install the stator and the rotor into a housing, you will need the following tools and materials:

- an installation tool as appropriate for your purposes
- a 0.2 mm thick shim (e.g., made from mylar)



To avoid any damage to the rotor, we recommend using non-magnetic tools.



For housing dimensions and other requirements, see the dimension drawings that are available for downloading at <https://rozum.com/frameless-documentation/>.

4.2 Assembly instructions

Below is a generic sequence of steps as required to install the rotor and the stator into a housing.



Handle the components of the frameless motor with care, especially the rotor, since its magnets are sensitive to mechanical shock.



Magnetic-sensitive objects, such as banking cards, pacemakers, or other magnetic information carriers, should be kept away at a distance of 1m from the rotor.

Step 1: Position your selected housing (see recommendations in **Section 1.4**) on a stable surface and fix it in place to prevent any sudden movements.

Step 2: Place the stator into the housing and secure it by bonding (see **Section 3.2**).

Step 3: Prepare the rotor assembly for installation. To do that, slide the rotor ring with magnets onto the rotor shaft and secure it either by clamping or by bonding (see **Section 3.3**).



Rare-earth magnets are brittle and chip easily. Therefore, take extra care when sliding the rotor ring onto the shaft and handling the assembly.

Step 4: Inside the stator ring, install a shim to prepare for fitting the rotor assembly.

Step 5: Lower the rotor assembly slowly and smoothly along the axis line to position it inside the stator ring.



During installation, the stator and rotor are exposed to strong attraction forces in axial and radial directions. For safe insertion, use special tooling that can provide smooth and gradual lowering of the rotor assembly along the axis line.

Step 6: Remove the shims.

Now, the motor is ready for further integration into your motion system. To complete the integration, you will need the additional equipment as listed in **Section 1.4**. The exact integration procedure will depend on the design of your system.



As a pre-commissioning test, you can rotate the motor manually to make sure it moves without stalling.

4.3 Disassembly

A generic disassembly practice is to follow the reverse order of the assembly sequence described in **Section 4.2**.

5 OPERATING CONDITIONS

Make sure that the location where the frameless motor is to be operated has a well-functioning exhaust system and is free from metal dust and debris. Other environmental specifications applicable to operation of FMI-series frameless motors are as listed in **Table 5-1**.

Table 5-1: Environmental specifications

Parameter	Specifications
Operating temperature	0 to 35°C
Operating humidity	80% max at 25°C (90% at 20°C)
Altitude	Not higher than 1,000 m above the sea
Atmosphere	Not suitable for use in explosive or hazardous atmospheres



Avoid exposing the motor to any environmental conditions outside of the listed specifications as this can cause damage to it.

6 MAINTENANCE

FMI-series frameless motors are essentially maintenance-free. However, it is advisable to check the motor regularly for the following:

- excessive or abnormal motor heating
- excessive motor vibrations
- loose couplings
- burning smells
- accumulation of debris, etc.

7 TROUBLESHOOTING

Table 7-1 lists the most common problems that can occur during operation of FMI-series frameless motors and their possible causes.

Table 7-1: Most common operation problems and their causes

Problem	Possible cause
You cannot turn the frameless motor by hand during the pre-commissioning test.	<ul style="list-style-type: none"> • There is a mechanical blockage. • Non-insulated parts of the two motor wires contact each other.
You have trouble starting the frameless motor.	<ul style="list-style-type: none"> • Broken wire—either inside the motor or outside it. • Incorrect installation of the rotor.

The motor generates excessive heat.	<ul style="list-style-type: none"> • Excessive load and operation outside the specifications (Table 2.1). • Defect of the motor winding. <p>To know the exact cause for sure, check operation of the motor at no load. If the motor is overheating even at no load, the cause is a winding defect. Otherwise, adjust the operation mode in accordance with the motor specifications.</p>
Excessive noise.	<ul style="list-style-type: none"> • Bearing defect. • Operation outside the motor specifications (Table 2-1).



Only qualified service personnel can perform repair works.

8 STORAGE

Prior to commissioning, it is advisable to store frameless motors in their shipping containers. Make sure to comply with the following storage requirements:

- For storing, choose a location with a controlled environment

Storage temperature: +5°C to +40°C

Storage humidity: 80% max at 25°C (90% at 20°C)

- Protect motor components from direct contact with magnetic materials or particles (e.g., iron chips, dust, etc.)

The **maximum storage period** is 10 years, provided the storage container is protected from humidity with silica gel.