

БЛSD.010201.300

A-A

Fig.1 A rotor assembled with a stator

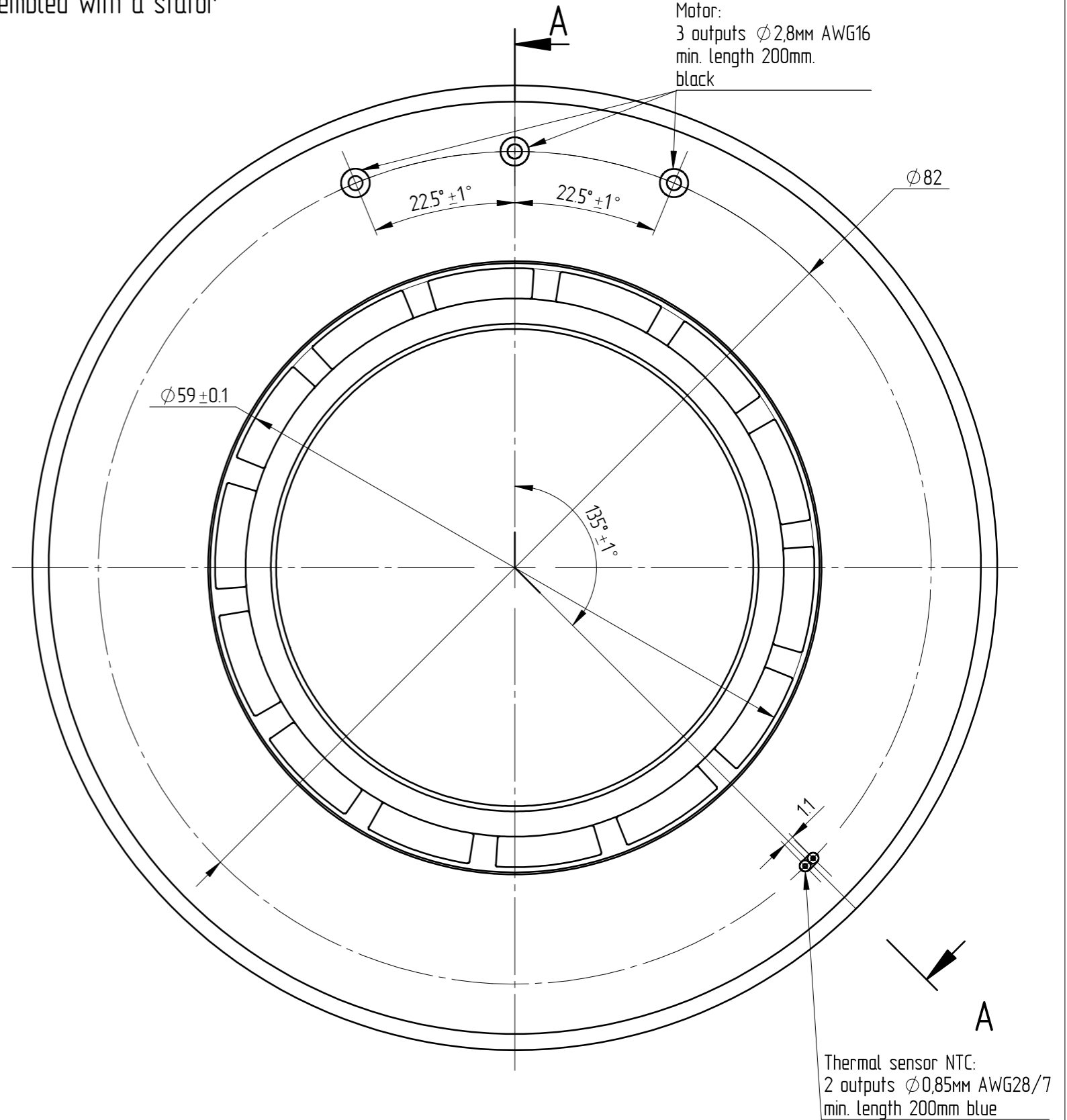
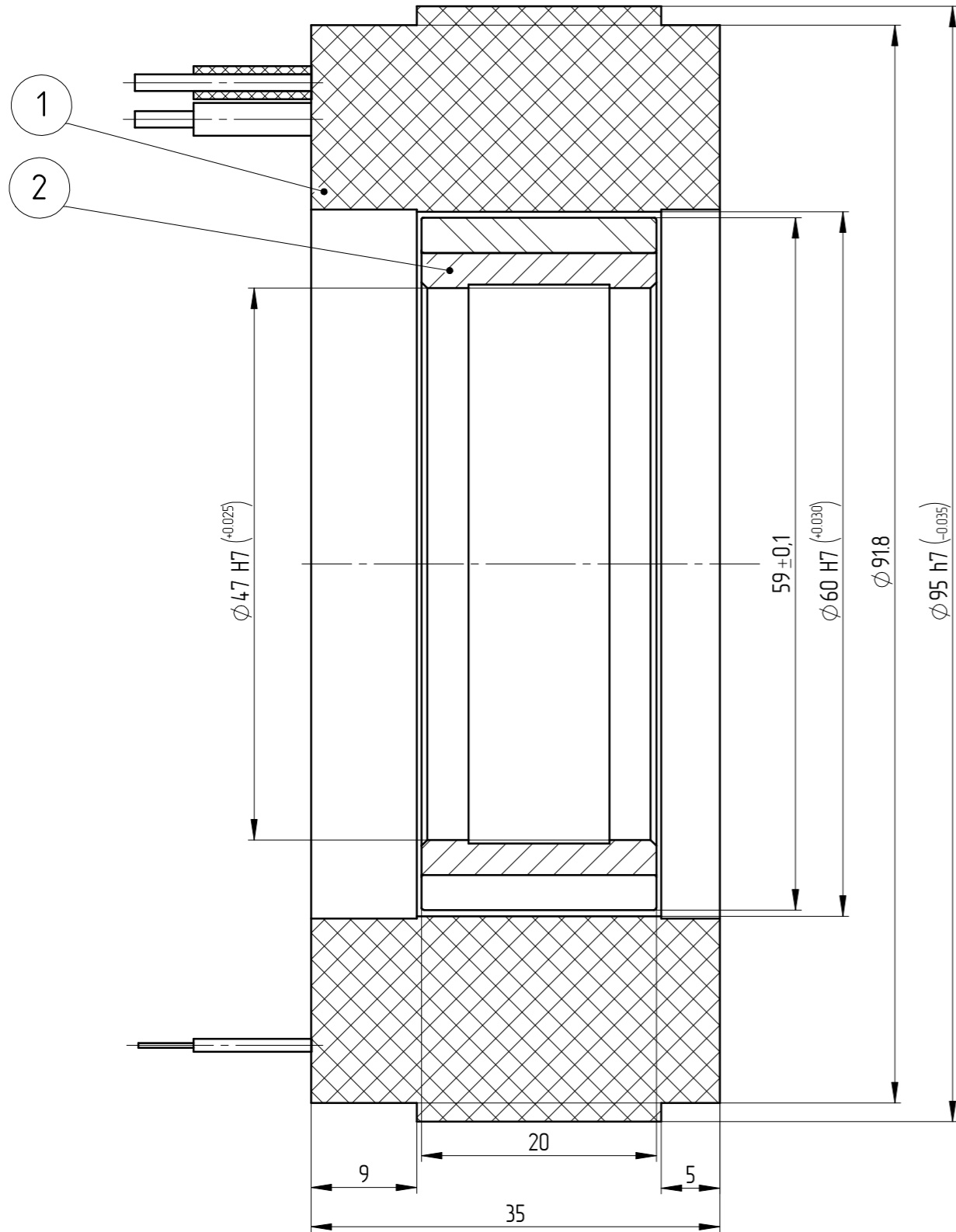

The dimensions are for reference.

Спроб. №	Подп. у дата	Инд. № дудл.	Взам. инд. №	Подп. у дата	Инд. № подл.

(01)			
Rev. Sheet	Document №	Signature	Date
Designed by	Rudzko		30.09.19
Checked by			
T. check			
Norm.check			
Appr. by			

BLSD.010201.400 DD

Frameless motor
FMI102001
Dimensional drawing

Letter	Weight	Scale
	0,8	2:1
Sheet	of 2 sheets	



Fig. 2 The rotor-stator assembly in a housing

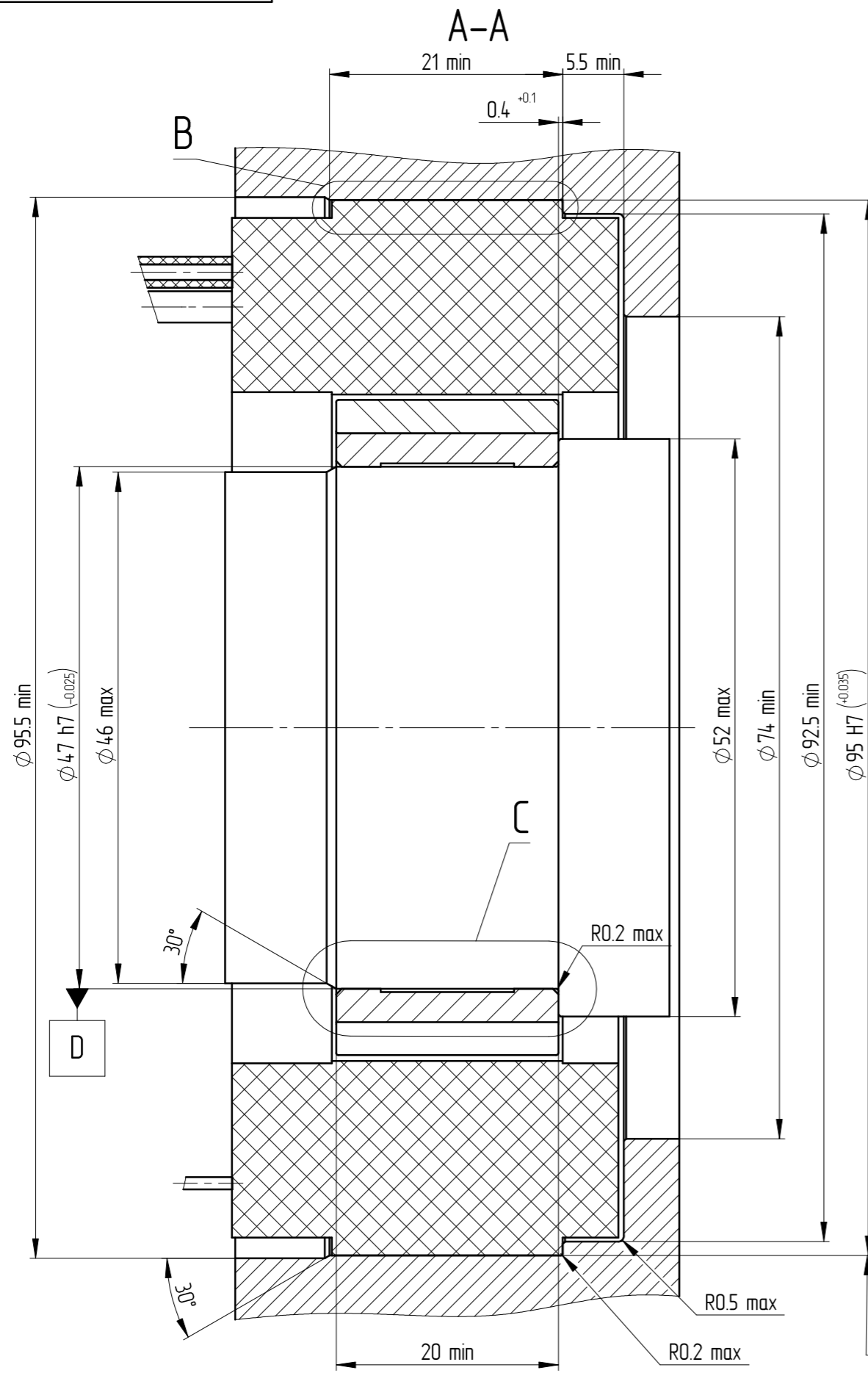

B (4 : 1)

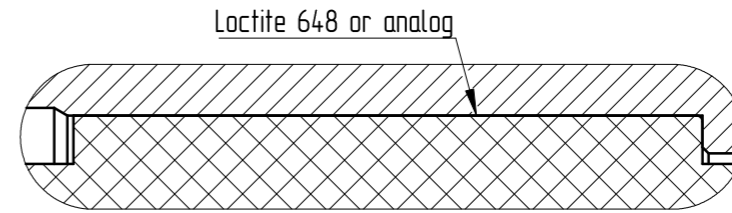

C (4 : 1)

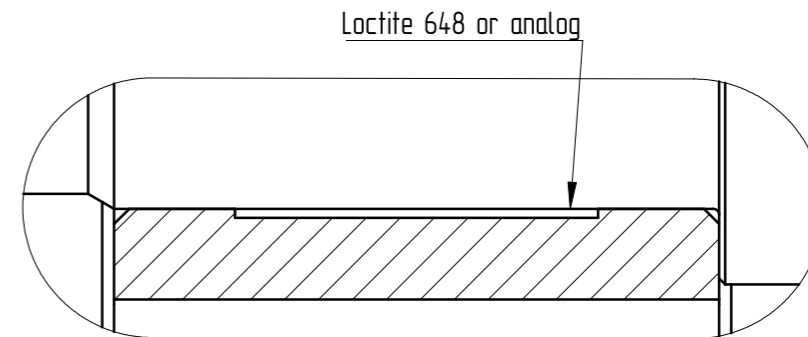

⊙ φ 0,05 D

Инд. № подл.	Подл. и дата	Взам. инд. №	Инд. № дубл.	Подл. и дата

(01)				
Rev.	Sheet	Document №	Signature	Date

BLSD.010201.400 DD

Sht.